

***USING TOTAL QUALITY TOOLS FOR MARKETING RESEARCH:
A QUALITATIVE APPROACH FOR COLLECTING, ORGANIZING, AND
ANALYZING VERBAL RESPONSE DATA***

STEVEN N. SILVERMAN, PH.D.

Green Grid Analytics & Strategy Group LLC
34511 Stellar Way SE
Snoqualmie, WA 98065
425 736 3725 (phone)
steven.silverman@greengridgroup.com (e-mail)

LORI L. SILVERMAN

Partners for Progress
5415 East McKellips Road, Unit 51
Mesa, AZ 85215
800 253 6398 (phone)
pfprogress@aol.com (e-mail)

ABSTRACT/INTRODUCTION

Tools for planning research efforts, and collecting and analyzing qualitative data are limited in marketing research. Two problems arise from this limitation. First, plans for collecting data are often under- or improperly-focused because the objectives of the research effort are not clearly specified. Second, researchers are often left with unstructured processes for analyzing the data generated from interviews or focus groups. Thus, tools that can help marketing researchers to plan their research efforts, and help to structure and analyze qualitative data, would be useful.

This paper introduces several such tools from the discipline of total quality management. These tools are useful in the planning of marketing research, as well as in the collection, organization, and analysis of qualitative marketing research data. First, we outline a potential gap in the marketing researcher's capability to analyze verbal data. Next, we introduce tools for addressing this gap, and describe the purpose(s) for which each tool can be applied in a marketing research context. The third and final section of the paper discusses how the tools can be *combined* to provide more thorough planning and even richer insight into collected data.¹

***MARKETING RESEARCHERS LACK TOOLS FOR ORGANIZING AND ANALYZING
VERBAL DATA***

Marketing researchers rarely explore problems that are "neat and clean." While clients may think they know what information they need, they may not be able to clearly specify their "decision

problem." Thus, they may ask for information which they believe will be useful, only to later find out that the study did not tell them what they needed to know. Because the research problem is not clearly specified, it is unlikely that useful data will be collected. Research problems remain unclear because there are no systematic means for framing them.

An analogous gap emerges in the process of analyzing qualitative, verbal response data. The marketing research field has few, if any, tools that a researcher can employ to systematically analyze collected data.

In both of these preceding cases, one must have a means of *organizing and assessing verbal information*. Managers (i.e., clients) verbalize the issues that they believe they are facing, and the marketing researcher must then formulate a research program. Similarly, customers may (for example) present their verbalizations regarding a new product concept, yet the researcher must then study this verbal data and draw useful conclusions from it. Unfortunately, marketing research lacks tools that can be used for organizing and analyzing verbal data.

USING THE SEVEN MANAGEMENT AND PLANNING TOOLS IN MARKETING

Marketing researchers face varied and complex challenges when planning and executing marketing research projects. It is, therefore, somewhat disappointing that the majority of efforts to improve the entire marketing research process have primarily addressed tools for collecting and analyzing numerical data, particularly using methods of statistical inference (see Barabba 1991, Barabba and Zaltman 1991). Systematic means for structuring research problems, *planning* research efforts, and *collecting and analyzing* qualitative data have been left virtually unstudied.

Yet, the nature of marketing planning and the analysis of qualitative data (specifically, verbal reports) actually are quite similar. Both require the creative and insightful structuring of thoughts to surface patterns of thinking. For instance, the planning of a research project requires careful insight into the formulation of the research question before any data collection methods can be thoughtfully selected. This process means analyzing the thoughts of marketing managers (or other customers of research efforts) in order to surface the crucial research questions. Similarly, the analysis of verbal response data (as from depth interviews or focus groups) requires a means of organizing the thoughts of many individuals to surface themes and issues in their thinking on a particular topic. Tools found in quality management address these issues.

Organizations that have adopted methods of statistical quality control are familiar with the seven basic tools of quality management (Kume 1985, Gitlow 1990).² These tools are primarily applied in the gathering and analysis of quantitative data. Furthermore, they are typically applied to systematic improvement of business processes. During the 1970s, a new set of tools were introduced in Japan that focus specifically on analysis of "verbal" information. These tools have come to be known collectively as The Seven New QC Tools (or, sometimes, The Seven

Management and Planning Tools). These tools are: Affinity Diagram, Relations Diagram, Systematic Diagram, Matrix Diagram, Matrix Data-Analysis, Process Decision Program Chart, and the Arrow Diagram. Dissemination and application of these tools has been slow since being introduced in the USA during the mid-1980s. Those few organizations that use these methods usually reserve them for analyzing "managerial" problems (primarily strategic planning). Few, if any, organizations have actually used these methods to address marketing- and customer-related issues. We will now introduce each of these tools (at a conceptual level) and describe how each can be used in marketing applications.

Affinity Diagram or KJ Method

The Affinity Diagram is a process for gathering ideas or opinions as verbal data and forming groupings of these thoughts based on the mutual affinity among the items. "This method expresses the facts, opinions, or ideas of a chaotic or uncertain problem in words (language data), and integrates the language data with affinity in an Affinity Diagram so as to find a problem, prospect the future, or conceive an idea" (Futami 1986, p. 8). In several ways this process is akin to a gut-level cluster analysis, similar to card-sorting techniques with which marketing researchers are familiar. Unlike most card sorting techniques, however, the diagram is created using *groups* of people. It is this group perspective which can lend additional insight that could not be gained from an individual level analysis. This is because the result must, by the rules of the task, be acceptable to all participants. Thus instead of representing exclusively an individual respondent's mental map (cf. Zaltman, LeMasters and Heffering 1982) what emerges is a group level phenomenon; a socially constructed representation of interrelationships as seen by an entire group.

Most groups construct an Affinity Diagram using the following method. First, a problem is posed in the form of a question. For example, a marketer might ask the following types of questions: "What are the problems one faces when preparing a meal for a family?" or "What makes it tough to keep a house clean?" Identifying the problem also implies the people who should be assembled to discuss the problem. In these examples, homemakers or housekeepers (respectively) might be asked to consider the question(s). Ideas are generated from among group members (e.g., in a focus group) using traditional methods like brainstorming, or silent idea generation. Usually, ideas from a group of eight or less can be generated and exhausted in under an hour. In other cases, such as a management issue, the problem can warrant several meetings to exhaust the factors from the group.

Ideas are then each transferred to a Post-it® note and stuck on the wall. Next, the Post-It® notes are arranged by a group working in silence. Ideas are arranged into clusters based on their

affinity with one another. The, groups of ideas are then labeled. No more than eight groupings of ideas are allowed. This helps themes to emerge from the data.

The Affinity Diagram is useful for understanding complex problems. It can help to overcome established ways of thinking by rearranging component parts of problems to see new relationships. The marketing researcher has at least three ways to use the Affinity Diagram process. The first is to independently organize data collected from a standard focus group process. In this case, a researcher would run a traditional focus group. Later, a group of researchers would then arrange the data to identify patterns. The "raw" focus group data can also be presented to the managers who requested the research, allowing them to create the sets of affinity relationships that they see.

The second usage of the affinity diagram allows the focus group to generate *and* organize the data. Here, the researcher would teach the focus group participants how to generate and organize information using the Affinity Diagram process. Then, after they understand the tool (which can be taught in under 30 minutes), they are coached through the process of answering the research question and arranging the data. Unlike any other focus group method, this method essentially asks the subjects to participate in some of the data analysis.

Finally, the researcher can pose the same problem question to a variety of groups. When using this approach, managers, suppliers, customers, etc., construct diagrams around the same problem question. Differences in their respective interpretations of the diagrams would spotlight gaps in the perceptions between the groups. A variation of this third usage would be using numerous teams to construct diagrams (i.e., several teams of customers, suppliers, managers, etc.). These diagrams could then be compared within and across populations for similarities and differences, providing greater sets of data for further analysis. If desired, distance measures, such as those used in Multi-Dimensional Scaling, could be used to analyze these data. With large enough sets of data, maps could be developed to display the dimensions upon which factors differ.

Example of the Affinity Diagram In Marketing Research³

The following example is a portion of a much larger Affinity Diagram presented by Futami (1989) that could have been generated by a group of consumers who were asked to "Describe a company which has a good corporate image." Figure 1 shows the results of the analyses that were assembled by the focus group participants themselves. The data generated from this method are clearly oriented toward discovering problems or ideas that are difficult to quantify. The method is particularly useful because of its ability to relate component issues to overall issues in a single representation. Therefore, it offers a unique complement to statistical methods often favored by marketing researchers.

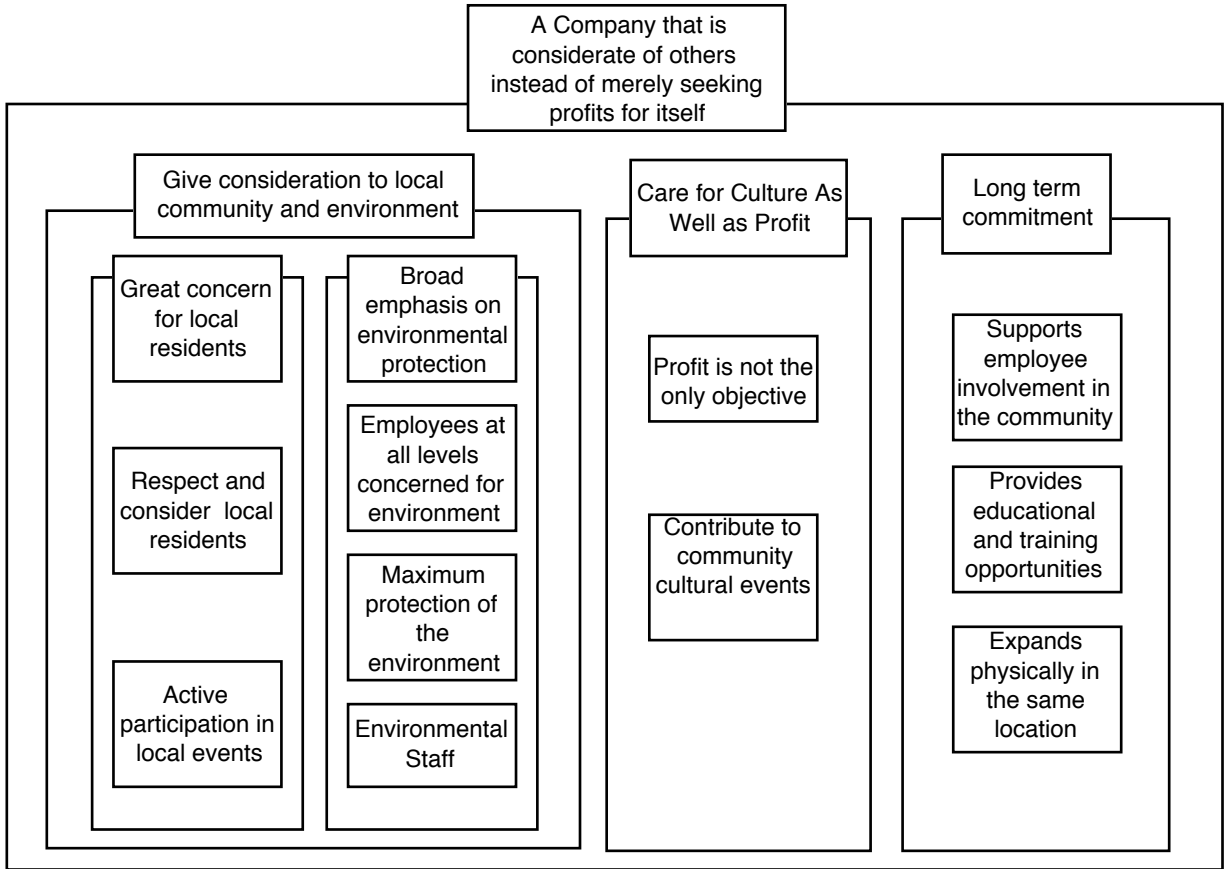

Figure 1
Affinity Diagram

Relations Diagram or Interrelationship Diagram

The primary purpose of the Relations Diagram Method is the identification of the complex causal interrelationships that may exist in a given situation (Mizuno 1988). The method presumes that there are many possible causes and effects surrounding a given "problem." The objective is to elicit the possible causes of the problem from those who are familiar with it. One studies the complexity of how these relationships are woven together in order to begin considering possible issues that can be addressed to "solve" the problem. The tool bears some resemblance to diagrams used in confirmatory factor analysis (e.g., LISREL).

Although we will not describe how to create the diagram, the following passage from Mizuno (1988) explains how to read the completed Relations Diagram:

In a relations diagram, short sentences or phrases expressing factors or problem points are enclosed in rectangles or ovals, and cause-and-effect relationships are indicated with arrows. The goal to be achieved or the problem to be solved is enclosed in a rectangle or oval, and important items or factors are shaded so that they can be more readily identified. As a rule, the arrow in a cause-and-effect format points from the cause to the effect. Likewise, in an objectives-means format, the arrow points from the means or measure taken to the objective. (p.93).

When the entire set of interrelationships has been identified, their relative importance as cause or effect elements is signified by the number of arrows going out or coming into each box, respectively.

There are three ways to identify the factors or problem points. One could use (1) the problem question and category titles from an Affinity Diagram, (2) one of the category titles and all of its component elements from an Affinity Diagram, or (3) topics generated from summarized focus group data. When using this method the researcher should recognize that it is not important that

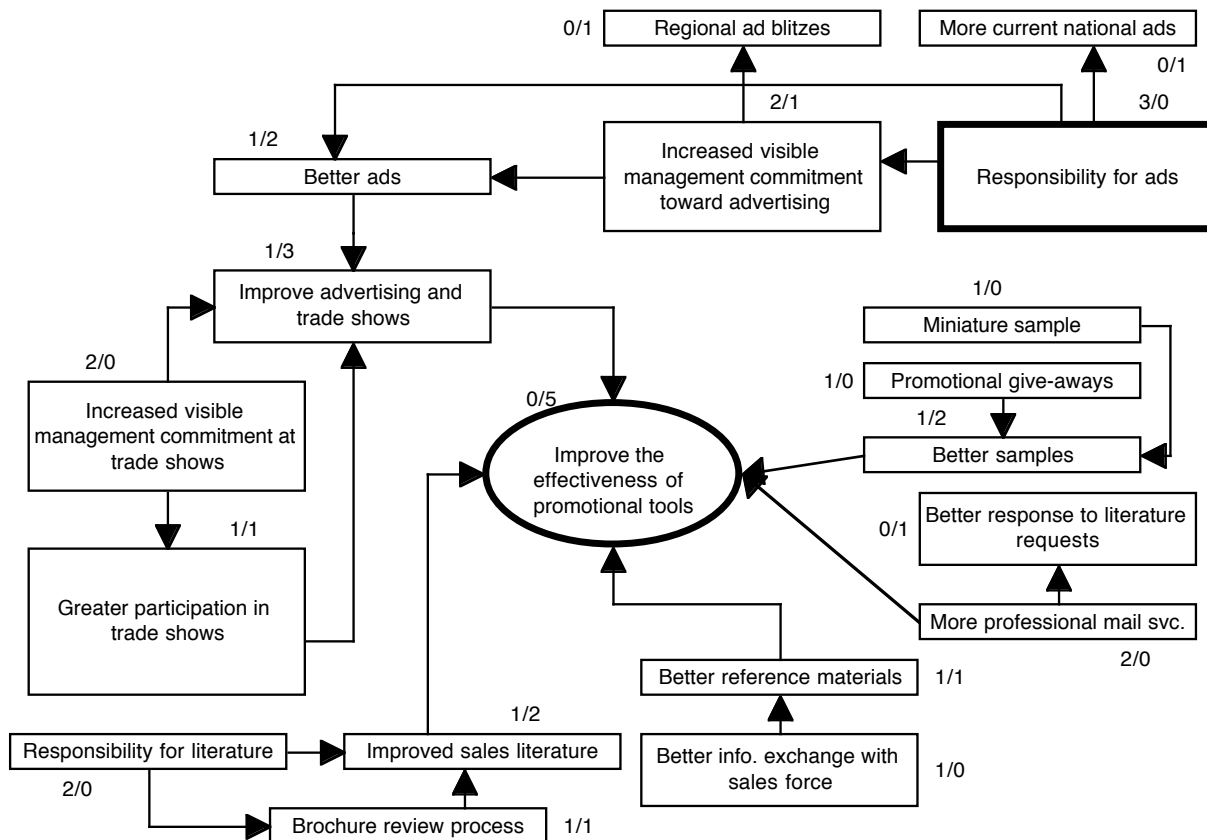

Figure 2
Relations Diagram

the groups that generate these diagrams actually describe the "correct" relationships (as we might assume are generated from statistical processes).

This tool is useful for (1) uncovering key causal factors, (2) identifying complex cause-and-effect relationships, and (3) identifying the critical elements in achieving an objective. In customer environments, one can identify key causal factors related to specific good or service problems. For example one might ask, "What causes a lousy movie theater experience?" Marketing managers could use the Relations Diagram to answer the question "Why do potential customers prefer our competitor's brand?" Cause and effect relationships might be studied by answering the question "what seems to be most strongly associated with our decrease in sales?". Finally, the tool can be adapted for use in creating a means for achieving a purpose such as "How to increase sales in the Northeast Region."

Example of the Relations Diagram In Marketing Research

Figure 2 shows a Relations Diagram developed to address a familiar marketing problem: the need to increase sales growth over the coming two years (Reist 1991). Specifically, the question was "What stands in the way of accelerated market penetration?" Here is a portion of their work (adapted from Reist 1991). The problem is shown with a circle; the key causal factor is shown with a bold border box.

Systematic Diagram or Tree Diagram

The Systematic Diagram is designed to *sequence* cause-effect relationships, or to identify means-end relationships. The objective outcome in both of these applications is to arrive at detailed, actionable items. In the second form of application discussed below, the objective-focused diagram, the outcome generated is akin to the outcome of a means-end analysis (Reynolds and Gutman, 1988).

Initially a team (e.g., a marketing research team) selects a critical problem or objective for which a plan needs to be made. A brainstorming session generates causes for the problem or means for achieving the objective. Alternatively, the data generated through an Affinity Diagram process or Relations Diagram process can be used as a starting point. Ideas are evaluated for actionability. For problem-focused diagrams, ideas are organized linearly based upon the causal relationships between the items (e.g., *b* causes *a*, and *c* causes *b*, etc.). In objective-focused diagrams, actions are linearly organized from the overall objective on the left side of the page, to the smallest actionable details on the right (e.g., *b* is the means to achieve *a*, and *c* is the means to achieve *b*, etc.). New ideas generated throughout the process will fill-in gaps.

There are at least two applications of the Systematic Diagram in marketing research. The first application is in the planning of marketing research efforts. Here, the tree will ultimately show all actions to be taken in order to complete a marketing research project. A second application

uses the tool to collect and analyze of consumer data. In this case customers would create the Systematic Diagram in non-traditional focus groups or depth interviews. For example, a leisure travel company might want to learn what customers think leads to a great family vacation. A group of potential vacationers, perhaps even a family unit, could be assembled and guided through a process of creating a systematic diagram. Ultimately the researcher will surface the component means that the consumers believe must be fulfilled in order to generate their desired outcome. An interpretation of this diagram will enhance a manager's understanding of how customers *believe* outcomes are related to causes. Regardless of whether this relationship is true, it is the belief which an individual or group holds about these relationships. To these people it is fact. Furthermore, if the leisure company had segmented focus groups into experienced and novice travelers, it could explore the differences between the groups.

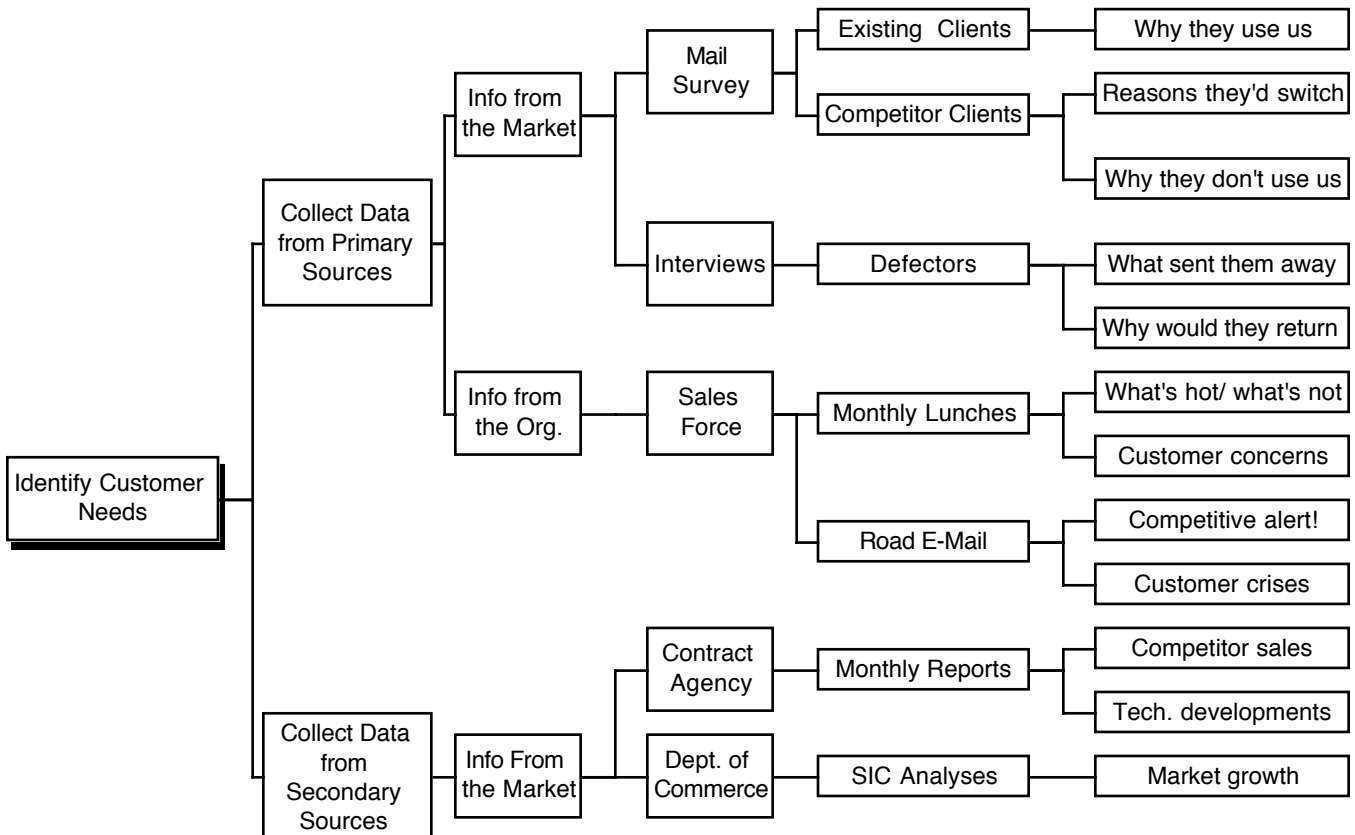

Figure 3
Systematic Diagram

Example of the Systematic Diagram in Marketing Research

Figure 3 is an example of an objective (i.e., means-end) focused systematic diagram. The objective here is "understanding customer needs." As the example suggests, the systematic analysis of the objective clarifies the means by which the objective will be achieved.

Matrix Diagram

A tool that has been well developed but not well utilized in marketing research is the Matrix Diagram. The purpose of this diagram is to relate to one another, in some fashion, two or more variable sets or list of items. In this section we discuss four different types of matrices: (1) L-Matrix, (2) T-Matrix, (3) Y-Matrix, and (4) X-Matrix.

In marketing, the use of matrices is primarily reserved for analyses of numerical information. Usually this involves an L-shaped matrix of statistical results that compares all options with themselves, or one other variable. These matrices, though helpful to investigators, are often confusing or of little value to naive readers. The remainder of the matrices discussed here do not resemble tools used in marketing.

The name of each matrix conveys the configuration of the matrix. The configuration of the matrix identifies the number of variable sets or item lists contained in the matrix. For example, an L-Matrix has an "L" shape and relates two variable sets or item lists. An X-Matrix has an "X" shape and relates four variable sets or item lists. The body of the matrix can convey strength of relationship, level of involvement, directionality or other information depending on the type of symbols used to create the matrix. The cells of intersection are used to designate these relationships.

Who Participates / Action Taken	Brand Manager	Research Manager	Research Associate	Agency	Customers
Specify Marketing Problem	◎	○			
Design Research Agenda	△	◎	○	△	
Design Data Collection Method	△	○	◎	△	
Design Sample Collect Data	△			◎	○
Analyze and Interpret Data	△	◎	○	○	
Prepare Research Report	△	○	◎		

◎ = Primary Responsibility
 ○ = Secondary Responsibility
 △ = Keep Informed

Figure 4
L-Shaped Matrix

The appropriate symbol for each cell of the matrix is usually determined in a meeting among the interested parties such as, marketing, marketing research, operations, etc. They discuss each relationship and come to consensus on the appropriate symbol code.

Matrices can be used (1) to interpret research data, (2) to form hypotheses, and (3) in the planning of research activities. For the sake of clarity, we will incorporate the marketing examples into the discussion of each matrix.

L-Matrix

The L-matrix is the most familiar type of matrix diagram to marketers. Two variable sets or item lists are positioned in a column and row format. The application shown in Figure 4 describes who is responsible for each specific step in a marketing research project. Here the cells symbols represent the relative level of responsibility for each member of the research team.

T-Matrix

The T-Matrix is a combination of two L-matrices that have a common variable set or item list. Figure five simultaneously identifies who uses and who collects different types of secondary marketing information.

Y-Matrix

The Y-Matrix lets a user compare three independent variable sets or item lists, two at a time. A generic picture of a Y-Matrix is shown in Figure 6. This matrix could be used by a marketing researcher to help a brand manager understand the relationships between and among products, users, and usage situations. It might also be used to uncover synergies between products, markets, and distributors, or other such relationships.

Government					◎	
Agency				◎	○	
Finance and Accounting		◎				
Operations		○				
Customer Service			△	◎		
Marketing Research	△	○	◎	◎	△	
Marketing Department	◎	○	△	◎	◎	
Who collects the Information?	Information Needed	Market Share	Sales	Brand Preference	Customer Satisfactor	Industry Trends
Who uses the Information?						
Brand Manager		◎	○	◎	◎	△
Sales Manager		○	◎	○	◎	△
Promotions Manager			○			○
Operations Manager						○
R & D Manager				○	○	◎
Planning Manager		○	○		△	◎

◎ = Primary Source/Customer
 ○ = Secondary Source/Customer
 △ = Occasional Source/Customer

Figure 5
T-Matrix

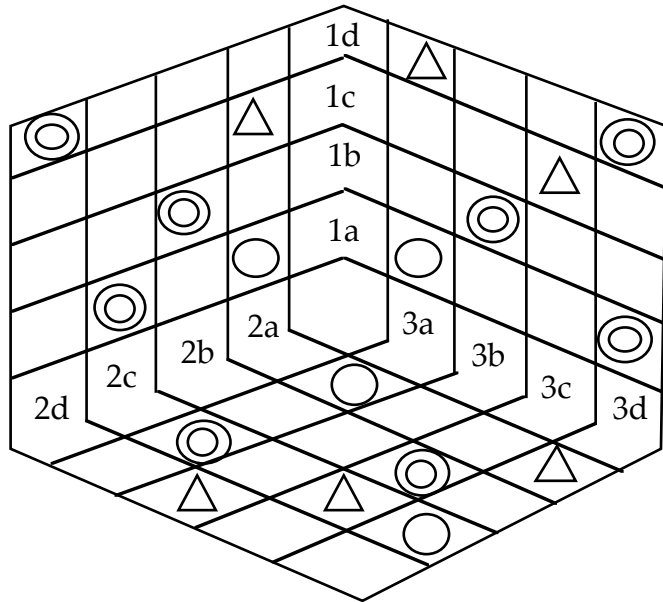

Figure 6
Y-Matrix

X-Matrix

Finally we can look at four variable sets or item lists, in pairs, using an X-Matrix.

Figure 7 shows a generic example of an X-Matrix. This type of matrix could be used to assess the relationships between company name, profit performance level, industry type, and growth rate. Caution must be taken in building the X-Matrix because factors on the same axis cannot be directly compared.

Process Decision Program Chart

The purpose of the Process Decision Program Chart (PDPC) is to develop contingencies to address possible failures

or troubles that could occur when executing specific actions listed in a plan. It does not relate to any tools currently used in marketing research.

The process for developing a PDPC is relatively straightforward. It involves asking "what

could go wrong when doing (or carrying out) _____?" Then a contingency plan(s) is developed for each identified problem. A PDPC can be used to identify potential problems and their countermeasures for each large branch on an existing Systematic Diagram.

This tool can be used to within a marketing research department or company as a means of jointly developing a project plan with an internal or external client. Figure 8 displays a PDPC for one branch of the Systematic Diagram presented earlier.

○			⊙		△	○		
	△	○		2d		△	○	⊙
△		⊙		2c			⊙	
	⊙			2b		⊙		
		○		2a			○	
1d	1c	1b	1a		3a	3b	3c	3d
	△		⊙	4a		△	○	
⊙			△	4b	○			△
	⊙			4c		⊙		⊙
○		○		4d			○	

Figure 7
X-Matrix

Specific problems are shown in the rectangles in the lower part of the diagram. The "balloons" contain the contingency plans for addressing each problem. When contingency plans are identified before a plan is implemented, specific activities can be built-into the proposed plan of action.

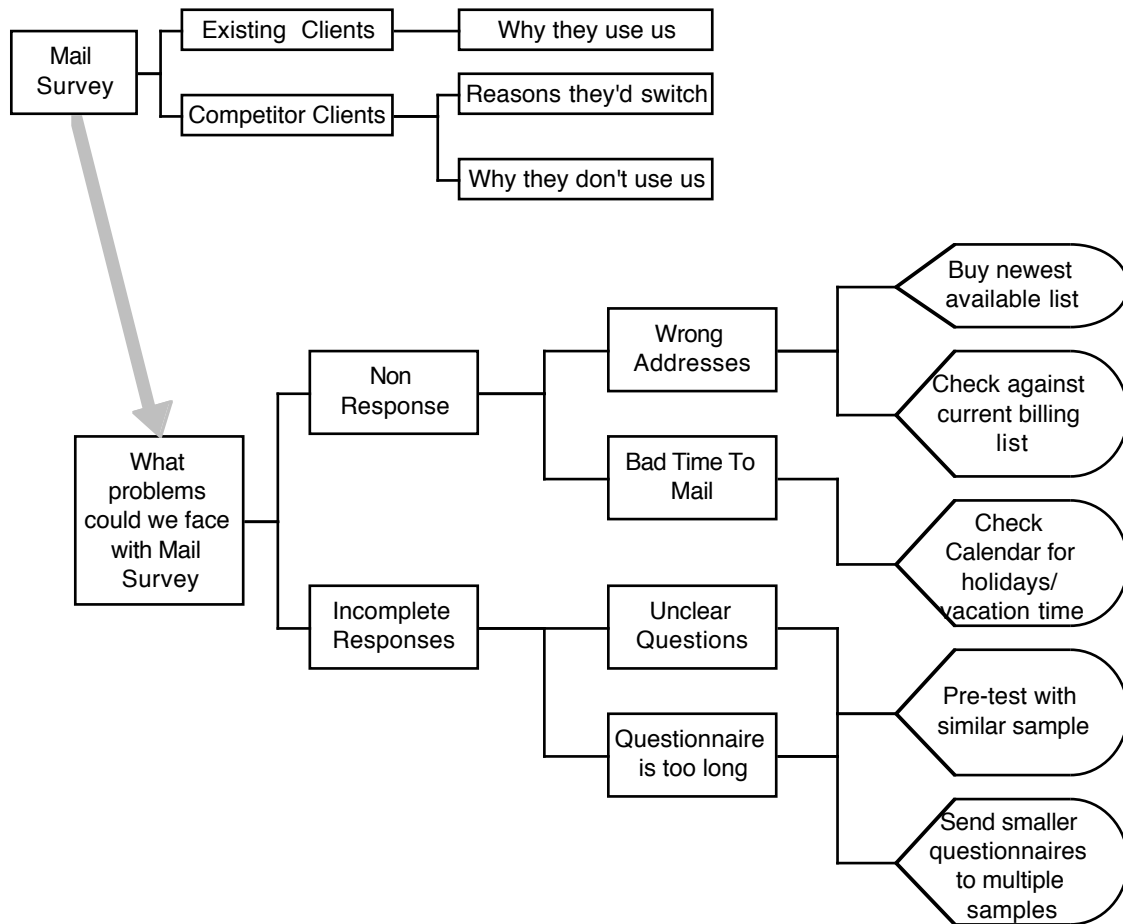

Figure 8
Process Decision Program Chart

Arrow Diagram or PERT Chart

An Arrow Diagram is used to specify the work sequence necessary to complete a set of activities in pursuit of an overall objective. In doing so the diagram also specifies when each action is to be finished. This tool is unrelated to any tools currently used in marketing.

First, an Arrow Diagram Flowchart is created to show the sequential order in which actions are to be undertaken to complete an action plan. An Arrow Diagram Flowchart can build on a Systematic Diagram (describing what needs to be done to achieve an objective) and PDPC (which suggests what needs to be done to avert potential problems). Alternatively, the components of the Arrow Diagram Flow Chart can be generated from a group brainstorm

session. Then an Arrow Diagram is constructed to clarify the chronological order for completing each action based on how long it will take to accomplish each action.

In marketing planning an Arrow Diagram Flowchart could be used to specify those actions that need to be taken (A, B, C, ...) in a planning process. Its associated Arrow Diagram would then display the date by which each action needed to be finished (time 1, 2, 3, ...) (see Figure 9).

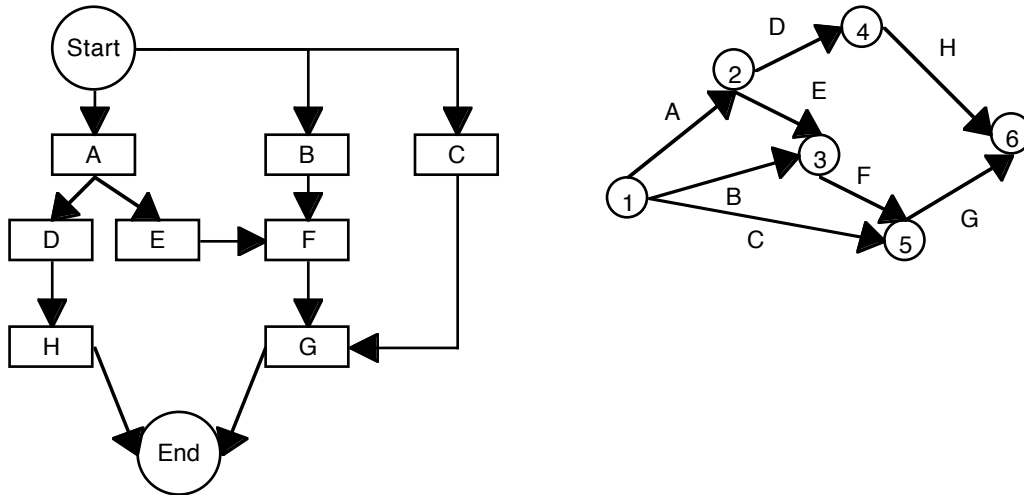

Figure 9
Arrow Diagram Flowchart (left) and Arrow Diagram (right)

Matrix-Data Analysis

The final tool in the Seven New QC Tools is referred to as Matrix Data-Analysis. Curiously, this tool already has significant recognition in marketing research. However in the marketing domain it is called Principle Components Analysis. Unlike the other tools discussed here, it relies on numerical data and on statistical principles to tease out the bases for correlations among many different factors. Because it is not at all new to marketers, and because it is less germane to the intent of this paper, this tool will not be discussed further here.

USING THE SEVEN NEW TOOLS TOGETHER

Until now, the Seven New QC Tools have been discussed as though most of them are separate from one another. Yet, as was suggested in some of the preceding discussion, these tools are intended to be used together in a systematic way to solve a given problem or address a particular issue. The flowchart shown in Figure 10 suggests one manner in which these tools can be linked together to conduct a marketing research inquiry.

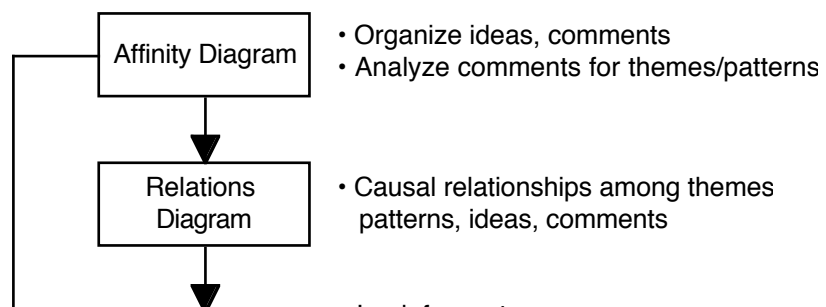

The process of creating an Affinity Diagram provides a rich basis for using several other tools in the set. Even if no other tools are used (which may be appropriate for many marketing applications), the Affinity Diagram can generate significant amounts of information in a group setting.

It is useful to study the relationships between the ideas, comments, themes and patterns that emerge from the Affinity Diagram. The Relations Diagram is designed for this purpose. Alternatively, one could proceed to a Systematic Diagram directly from the Affinity Diagram process. This approach allows one to search for a root cause(s) among the issues that have emerged. The Relations Diagram can also be used as an input into the Systematic Diagram because it outlines causal relationships.

A Systematic Diagram can lead one to further explore the complexities of the issue by interrelating diagram components with one another using one or more Matrix Diagrams. Matrices can be useful in showing how many of the issues are associated with one another. Further study can be guided by Matrix-Data Analysis.

Alternatively, one can proceed from a Systematic Diagram to the development of a Process Decision Program Chart to better expose the potential pitfalls in the efforts suggested by the Systematic Diagram. From this information, an Arrow Diagram specifying the process that will be used to address the problem under study can be developed. This Arrow Diagram can benefit from the PDPC analysis by incorporating additional time to address contingency plans associated with identified problems.

CONCLUSION

The primary function of this paper has been to introduce to marketing researchers a variety of tools that have been used in the quality management area. These tools are known collectively as the Seven New QC Tools. These tools can be used as a system, or individually, to address a wide range of marketing research issues. The means by which the tools should be employed (individually or together) is up to the discretion of the researcher given the nature of the problem or project. Marketing researchers can apply the tools in (a) planning their research efforts, and (b) collecting verbal response data that are otherwise difficult to analyze. These tools can be improved and their applications more fully explored as they are incorporated into marketing research.

Our discussion focuses primarily on applications to qualitative data analysis. However, the tools could conceivably also be applied in a quantitative context.

¹It is important to note that this paper does not describe *how* to develop each of the tools. The reader is referred to Brassard (1989), Mizuno (1988), and Gitlow (1990) for detailed information on how to actually develop each tool in an application setting.

²These tools are: check sheets, Pareto analysis, cause-and-effect diagrams, histograms, scatter diagrams, control charts, and run charts.

³Unless otherwise noted, the examples presented here are only representative of how a given method can be employed and do not represent the results of an actual research effort.

REFERENCES

- Akao, Yoji (1990), *Quality Function Deployment: Integrating Customer Requirements into Product Design*, Cambridge MA: Productivity Press.
- Barabba, Vincent P. (1991), "The Market Research Encyclopedia," *Harvard Business Review*, 90 (January-February) 105-116.
- Barabba, Vincent P., and Gerald Zaltman (1991), *Hearing the Voice of the Market*, Cambridge MA: Harvard Business School Press.
- Brassard, Michael (1989), *The Memory Jogger Plus+*, Methuen, MA: GOAL/QPC.
- Futami, Ryoji (1986), "The Outline of Seven Management Tools for QC," *Reports of Statistical Application Research, Union of Japanese Scientists and Engineers*, 33 (June) 7-26.
- Futami, Ryoji (1989), *An Overview of Seven Management Tools for QC*, Tokyo, Japan: Union of Japanese Scientists and Engineers.
- Gitlow, Howard (1990), *Planning for Quality, Productivity, and Competitive Position*, Homewood, IL: Dow Jones - Irwin.
- Kume, Hitoshi (1985), *Statistical Methods for Quality Improvement*, Tokyo, Japan: The Association for Overseas Technical Scholarship.
- Mizuno, Shigeru (1988), *Management for Quality Improvement*, Cambridge MA: Productivity Press.
- Peter, J. Paul, and James H. Donnelly, Jr., (1985), *A Preface to Marketing Management*, 3rd ed., Plano, TX: Business Publications, Inc.
- Reist, Stephen N. (1991), "Process Improvement: Utilizing Total Quality Management Techniques for Sales and Marketing," in conference proceedings *Adapting Japanese TQC for the West*, Minneapolis, MN: Process Management International.
- Reynolds, Thomas J., and Jonathan Gutman (1988), "Laddering Theory, Method, Analysis, and Interpretation," *Journal of Advertising Research*, (February/March), 11-31.
- Zaltman, Gerald, Karen LeMasters, and Michael Heffring (1982), *Theory Construction in Marketing*, New York: John Wiley and Sons.